

New insert pocket for fine finish boring

using improved geometries as: TP.. 0902.. & TP.. 1103..



- *11° relief angle* will enlarge customer choices that already had 7° relief angle in PINZBOHR programme.
- We introduce these new models either in *75° & 90° angle approach* from 22 size head up to 500 size heads.
- PINZBOHR features one of the widest ranges of insert pocket geometries to meet customers needs.

INTEGRAL POCKET TYPE HEADS

NEW FINISH BORING HEADS

ADJUSTING ACCURACY 0.002 mm Ø

FINISH HEADS
75° APPROACH

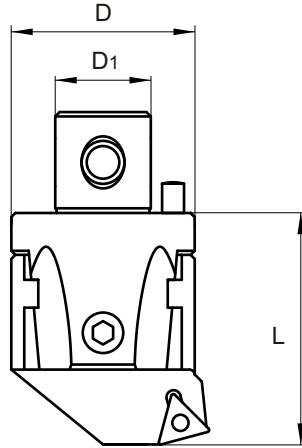

Bore Range		Dimension			Product Number	Insert	Clamp Screw	Kg.	Adj. Key / Clamp Key / Locking Key		
Min	Max	øD	øD1	L					Adj. Key	Clamp Key	Locking Key
24	30	22	12	34	A22 75 310	TP.. 0902.. *	TT 400	0.080	2	T8	3
29	40	27	15	42	A27 75 310	TP.. 0902.. *	TT 400	0.180	2	T8	4
39	50	32	20	45	A32 75 310	TP.. 0902.. *	TT 400	0.250	2.5	T8	4
49	65	42	24	56	A42 75 311	TP.. 1103.. *	TT 401	0.580	3	T10	5
63	82	54	28	66	A54 75 311	TP.. 1103.. *	TT 401	1.050	3	T10	6

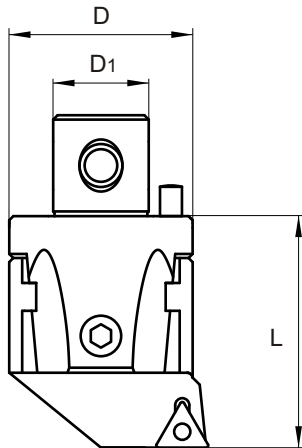

FINISH HEADS
90° APPROACH

Bore Range		Dimension			Product Number	Insert	Clamp Screw	Kg.	Adj. Key / Clamp Key / Locking Key		
Min	Max	øD	øD1	L					Adj. Key	Clamp Key	Locking Key
24	30	22	12	34	A22 90 310	TP.. 0902.. *	TT 400	0.080	2	T8	3
29	40	27	15	42	A27 90 310	TP.. 0902.. *	TT 400	0.180	2	T8	4
39	50	32	20	45	A32 90 310	TP.. 0902.. *	TT 400	0.250	2.5	T8	4
49	65	42	24	56	A42 90 311	TP.. 1103.. *	TT 401	0.580	3	T10	5
63	82	54	28	66	A54 90 311	TP.. 1103.. *	TT 401	1.050	3	T10	6

* THE BEST FINISH RESULTS ARE ACHIEVABLE WITH INSERTS: TPGH 0902.. L OR TPGX 0902.. L
 * THE BEST FINISH RESULTS ARE ACHIEVABLE WITH INSERTS: TPGH 1103.. L OR TPGX 1103.. L

CARTRIDGE TYPE HEADS

NEW FINISH BORING HEADS

ADJUSTING ACCURACY 0.002 mm Ø

FINISH HEADS
75° APPROACH

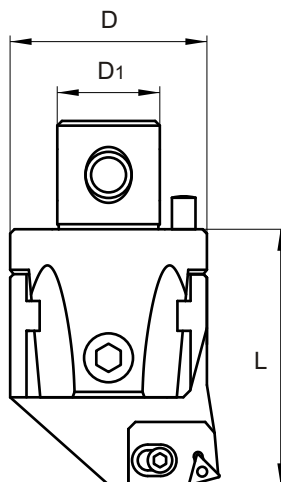

Bore Range		Dimension			Product Number	Cartridge *	Clamp Screw	Kg.	Key		
Min	Max	øD	øD1	L					Adj. Key	Clamp Key	Locking Key
80	102	68	36	86	A68 75 311	2CT 75 311	TT 401	2.175	5	T10	8
100	125	85	50	100	A85 75 311	3CT 75 311	TT 401	4.200	6	T10	8
125	160	110	60	100	A100 75 311	3CT 75 311	TT 401	6.600	6	T10	8
160	220	145	60	100	A200 75 311	3CT 75 311	TT 401	8.960	6	T10	8

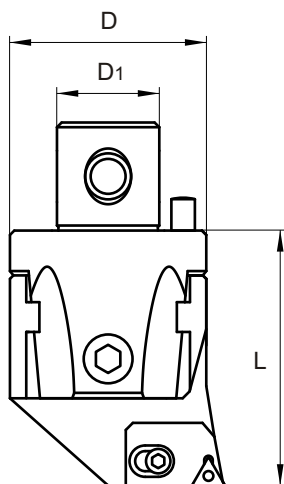

FINISH HEADS
90° APPROACH

Bore Range		Dimension			Product Number	Cartridge *	Clamp Screw	Kg.	Key		
Min	Max	øD	øD1	L					Adj. Key	Clamp Key	Locking Key
80	102	68	36	86	A68 90 311	2CT 90 311	TT 401	2.175	5	T10	8
100	125	85	50	100	A85 90 311	3CT 90 311	TT 401	4.200	6	T10	8
125	160	110	60	100	A100 90 311	3CT 90 311	TT 401	6.600	6	T10	8
160	220	145	60	100	A200 90 311	3CT 90 311	TT 401	8.960	6	T10	8

* FULL CARTRIDGE INFORMATION (INCLUDING INSERT SIZE) IN BACKCOVER

LARGE DIAMETER CARTRIDGE TYPE HEADS

NEW FINISH BORING HEADS

ADJUSTING ACCURACY 0.002 mm Ø

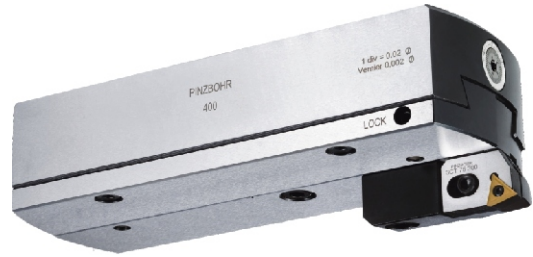
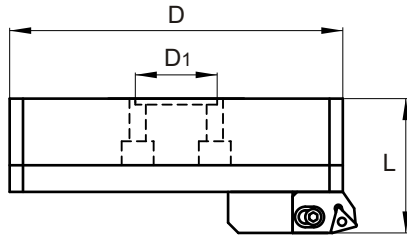

FINISH HEADS 75° APPROACH

Bore Range Min Max	Dimension			Product Number	Cartridge	Clamp Screw	Kg.	Adj. Key			Clamp Key		Locking Key	
	ØD	ØD1	L											
220 320	202	60	90	A300 75 311	3CT 75 311	TT 401	9.300	5	T10	4				
290 400	272	60	90	A400 75 311	3CT 75 311	TT 401	12.950	5	T10	4				
370 500	352	60	90	A500 75 311	3CT 75 311	TT 401	16.250	5	T10	4				

FINISH HEADS 90° APPROACH

Bore Range Min Max	Dimension			Product Number	Cartridge	Clamp Screw	Kg.	Adj. Key			Clamp Key		Locking Key	
	ØD	ØD1	L											
220 320	202	60	90	A300 90 311	3CT 90 311	TT 401	9.300	5	T10	4				
290 400	272	60	90	A400 90 311	3CT 90 311	TT 401	12.950	5	T10	4				
370 500	352	60	90	A500 90 311	3CT 90 311	TT 401	16.250	5	T10	4				

INDEXABLE STANDARD CARTRIDGES

TYPE 90 311

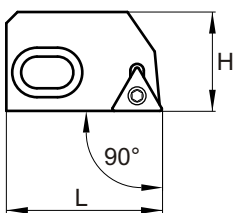

TYPE 75 311

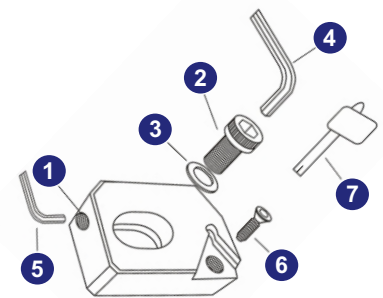
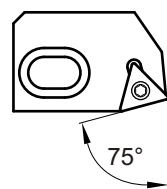

Product Number	Dimension		Kg.	Insert	1	2	3	4	5	6	7
	H	L									
2CT 75 311	22.5	35	0.050	TP.. 1103.. *	D 68 29	A 68 26	D 68 28	5	2	TT 401	T10
2CT 90 311	22.5	35	0.050	TP.. 1103.. *	D 68 29	A 68 26	D 68 28	5	2	TT 401	T10
3CT 75 311	28	39	0.100	TP.. 1103.. *	D 85 29	D 85 27	D 68 28	5	3	TT 401	T10
3CT 90 311	28	39	0.100	TP.. 1103.. *	D 85 29	D 85 27	D 68 28	5	3	TT 401	T10

* THE BEST FINISH RESULTS ARE ACHIEVABLE WITH INSERTS: TPGH 1103.. L OR TPGX 1103.. L