

**Nuevo asiento de plaquita para acabados de alta precisión
usando geometrías de corte: TP.. 0902.. & TP.. 1103..**



- Las plaquitas de 11° de incidencia amplían el programa estándar PINZBOHR de 7° de incidencia.
- Esta novedad contempla todos los cabezales de acabado tanto de 75° como 90° de aproximación.
- PINZBOHR ofrece la gama más amplia de geometrías de corte para un mismo modelo de cabezal.

CABEZALES CON ASIENTO DE PLAQUITA INTEGRADO

AJUSTE RADIAL DE 0.002 mm Ø



CABEZALES DE ACABADO 75°

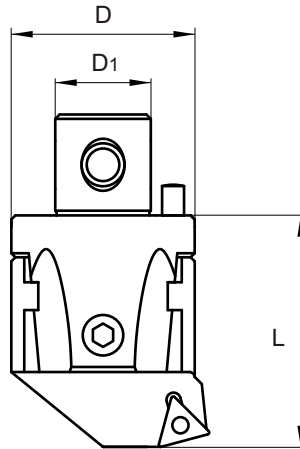

Capacidad		Dimensiones			Código de producto	Plaquita	Tilo. Fijación Plaquita	Kg.	Llave de Ajuste		
Mín	Máx	øD	øD1	L					TK	TK	TK
24	30	22	12	34	A 02275 310	TP□□ 0902□□	TT 400	0.100	HK 020	TK 08	HK 030
29	40	27	15	42	A 02775 310	TP□□ 0902□□	TT 400	0.160	HK 020	TK 08	HK 040
39	50	32	20	45	A 03275 310	TP□□ 0902□□	TT 400	0.250	HK 025	TK 08	HK 040
49	65	42	24	56	A 04275 311	TP□□ 1103□□	TT 401	0.510	HK 030	TK 10	HK 050
63	82	54	28	66	A 05475 311	TP□□ 1103□□	TT 401	1.020	HK 030	TK 10	HK 060

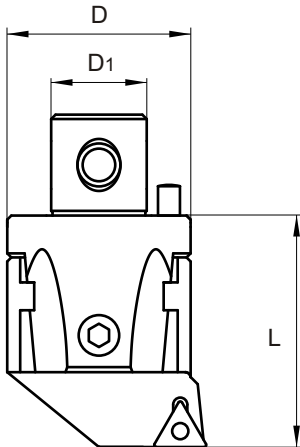

CABEZALES DE ACABADO 90°

Capacidad		Dimensiones			Código de producto	Plaquita	Tilo. Fijación Plaquita	Kg.	Llave de Ajuste		
Mín	Máx	øD	øD1	L					TK	TK	TK
24	30	22	12	34	A 02290 310	TP□□ 0902□□	TT 400	0.100	HK 020	TK 08	HK 030
29	40	27	15	42	A 02790 310	TP□□ 0902□□	TT 400	0.160	HK 020	TK 08	HK 040
39	50	32	20	45	A 03290 310	TP□□ 0902□□	TT 400	0.250	HK 025	TK 08	HK 040
49	65	42	24	56	A 04290 311	TP□□ 1103□□	TT 401	0.510	HK 030	TK 10	HK 050
63	82	54	28	66	A 05490 311	TP□□ 1103□□	TT 401	1.020	HK 030	TK 10	HK 060

CABEZALES CON CARTUCHO INTERCAMBIABLE

AJUSTE RADIAL DE 0.002 mm Ø 

CABEZALES DE ACABADO **75°**

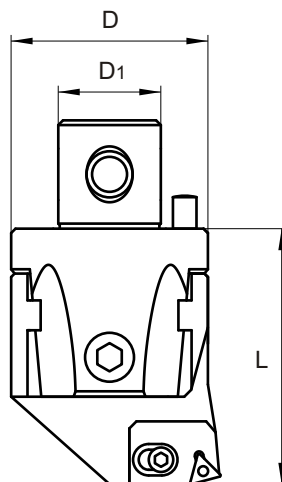

Capacidad		Dimensiones			Código de producto	Cartucho *	Tllo. Fijación Plaquita	Kg.	Llave de Ajuste		
Mín	Máx	øD	øD1	L					Tornillo Bloqueo	Llave Bloqueo	
80	102	68	36	86	A 06875 311	2CT 75 311	TT 401	2.050	HK 050	TK 10	HK 080
100	125	85	50	100	A 08575 311	3CT 75 311	TT 401	3.930	HK 060	TK 10	HK 080
125	160	110	60	100	A 10075 311	3CT 75 311	TT 401	6.250	HK 060	TK 10	HK 080
160	220	145	60	100	A 20075 311	3CT 75 311	TT 401	8.330	HK 060	TK 10	HK 080

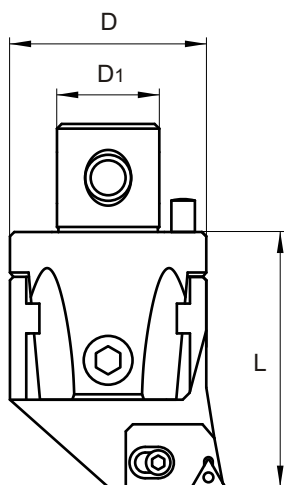

CABEZALES DE ACABADO **90°**

Capacidad		Dimensiones			Código de producto	Cartucho *	Tllo. Fijación Plaquita	Kg.	Llave de Ajuste		
Mín	Máx	øD	øD1	L					Tornillo Bloqueo	Llave Bloqueo	
80	102	68	36	86	A 06890 311	2CT 90 311	TT 401	2.050	HK 050	TK 10	HK 080
100	125	85	50	100	A 08590 311	3CT 90 311	TT 401	3.930	HK 060	TK 10	HK 080
125	160	110	60	100	A 10090 311	3CT 90 311	TT 401	6.250	HK 060	TK 10	HK 080
160	220	145	60	100	A 20090 311	3CT 90 311	TT 401	8.330	HK 060	TK 10	HK 080

* TODA LA INFORMACION DEL CARTUCHO (INCLUIDO TAMAÑO DE PLAQUITA) EN PAGINA DE ATRAS

CABEZALES DE GRAN Ø CON CARTUCHO INTERCAMBIABLE

AJUSTE RADIAL DE 0.002 mm Ø

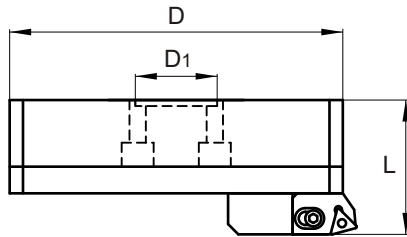

CABEZALES DE ACABADO 75°

Capacidad		Dimensiones			Código de producto	Cartucho	Tllo. Fijación Plaquita	Kg.	Llave de Ajuste		
Mín	Máx	øD	øD1	L					Tornillo Bloqueo	Llave Bloqueo	
220	320	202	60	90	A 30075 311	3CT 75 311	TT 401	8.750	HK 050	TK 10	HK 040
290	400	272	60	90	A 40075 311	3CT 75 311	TT 401	12.200	HK 050	TK 10	HK 040
370	500	352	60	90	A 50075 311	3CT 75 311	TT 401	16.310	HK 050	TK 10	HK 040

CABEZALES DE ACABADO 90°

Capacidad		Dimensiones			Código de producto	Cartucho	Tllo. Fijación Plaquita	Kg.	Llave de Ajuste		
Mín	Máx	øD	øD1	L					Tornillo Bloqueo	Llave Bloqueo	
220	320	202	60	90	A 30090 311	3CT 90 311	TT 401	8.750	HK 050	TK 10	HK 040
290	400	272	60	90	A 40090 311	3CT 90 311	TT 401	12.200	HK 050	TK 10	HK 040
370	500	352	60	90	A 50090 311	3CT 90 311	TT 401	16.310	HK 050	TK 10	HK 040

CARTUCHOS INTERCAMBIABLES ESTANDAR

TIPO 90 311

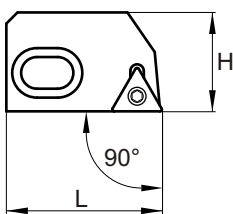

TIPO 75 311

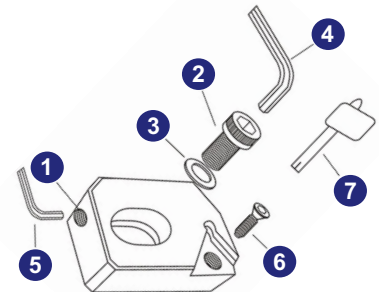
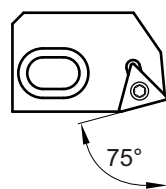

Código de producto	Dimensiones		Kg.	Plaquita	1	2	3	4	5	6	7
	H	L			D	A	D	HK	HK	TT	TK
2CT 75 311	22.5	35	0.050	TP□□ 1103□□	D 068 29	A 068 26	D 068 28	HK 050	HK 020	TT 401	TK 10
2CT 90 311	22.5	35	0.050	TP□□ 1103□□	D 068 29	A 068 26	D 068 28	HK 050	HK 020	TT 401	TK 10
3CT 75 311	28	39	0.100	TP□□ 1103□□	D 085 29	D 085 27	D 068 28	HK 050	HK 030	TT 401	TK 10
3CT 90 311	28	39	0.100	TP□□ 1103□□	D 085 29	D 085 27	D 068 28	HK 050	HK 030	TT 401	TK 10